



POWERLINE 14

**INSULATED CONDUCTOR RAIL
FOR ELECTRICAL FEEDING OF CRANES**

Features, advantages and benefit

A complete programme of feeding and control lines of mobile machines for loads up to 2000 A. We have a choice of technical solutions for every demand of feeding of cranes, hoists, handling and stocking systems, as well as assembling systems. Our firm attention to R&D of new solutions allows to transfer the most advanced technologies in our trade marks leader in the market: Atollo, Isol/Car, Stripe, **PowerLine 14**, Speed. Our production programme is completed with mono and bi-metallic contact rails, and festoon lines up to 600Kg. of capacity and travel speed up to 300m/min, sliding in rails, on profiles of square tube and IPE/IPN track rails for round and flat cables. Our technical support staff can advice you on the particular product which is most suitable for your specific application.

CARIBONI, series **PowerLine 14** is a modern electricity power supply system for electrified monorails (EMS), hoists, cranes, assembly lines and handling devices in general. The system is also able to transmit data and signals.

PowerLine 14 complies with the safety features demanded from an electric power supply system or the latest generation. Protection against accidental contacts is guaranteed and the earth conductor is identified by a yellow-green housing.

PowerLine 14 allows several single pole conductors to be assembled easily until the required configuration is reached, all taking up very little space. Curves, uphill and downhill sections can be installed using **PowerLine 14** and the system can operate with conductors superimposed vertically or paired horizontally.

PowerLine 14 is suitable for powering electrified overhead monorails (EMS) fitted with self-drive trolleys. The components for these applications are made in a multi-pole version and the system is completed by specific assembly accessories.

PowerLine 14 has been devised to facilitate conductor assembly by installers, guarantee limited maintenance and ensure fast, safe replacement of the sliding shoes of the current collector.

ISO9001

ISO14001

BS OHSAS 18001

CE MARK: it guarantees that Cariboni's products are complying with the European standards concerning safety of products.



- 1 Insulated Contact Rail
- 2 Single Pole Joint Clamp
- 3 Multi-pole Joint Clamp
- 4 Feeder Clamp between two Rail Sections
- 5 Intermediate Feeder Clamp to the Rail Section
- 6 Straight Transfer Terminal
- 7 Oblique Transfer Terminal
- 8 Single Pole Support Hanger
- 9 Multi-pole Support (8 poles)
- 10 Fixing Bar for Transfer Terminal
- 11 Sectionalizing Joint
- 12 Expansion Joint
- 13 Fixed Point Clamp
- 14 Feeder Cable for Rail
- 15 Feeder Cable for Current Collector
- 16 Current Collector
- 17 Current Collectors Holder Plate

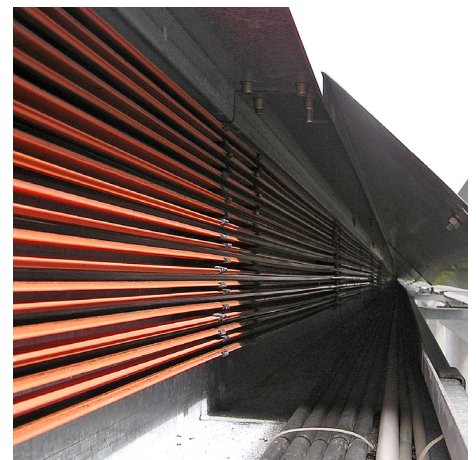
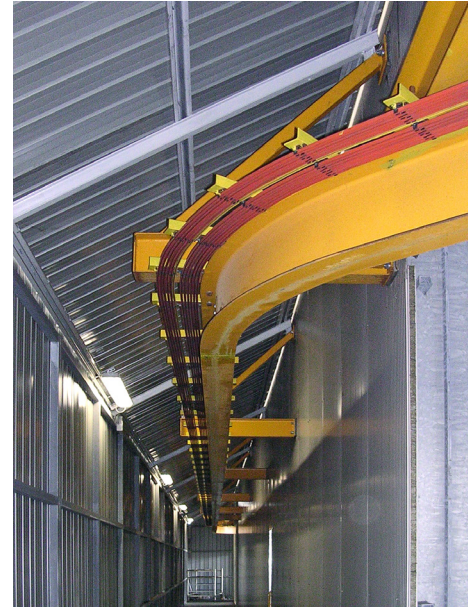

Technical specifications

Operating voltage	max 600 V
Continuous load (at a temperature of 20 °C)	100 Amp
Environment temperature range	-30 +55 °C
Maximum travelling speed	300 m/1'
Nominal length of rail sections	6 m
Inter - axis between conductors	14 mm
Minimum bending radius	0.4 m
Distance between hangers - straight line	0.75 m
Distance between hangers - curved line	max 0.3 m
Protection degree (as per EN 60529)	IP 2X
Inflammability (as per En 60695-2-2)	Self-extinguishing

Conductor material	Load (A)	Cross-section Conductor	Resistance at 20°C $\Omega/m 10^{-4}$	Impedance at 50 Hz $\Omega/m 10^{-4}$
Copper	100	24	7.44	7.43

Solution with single pole support hangers and joint clamps

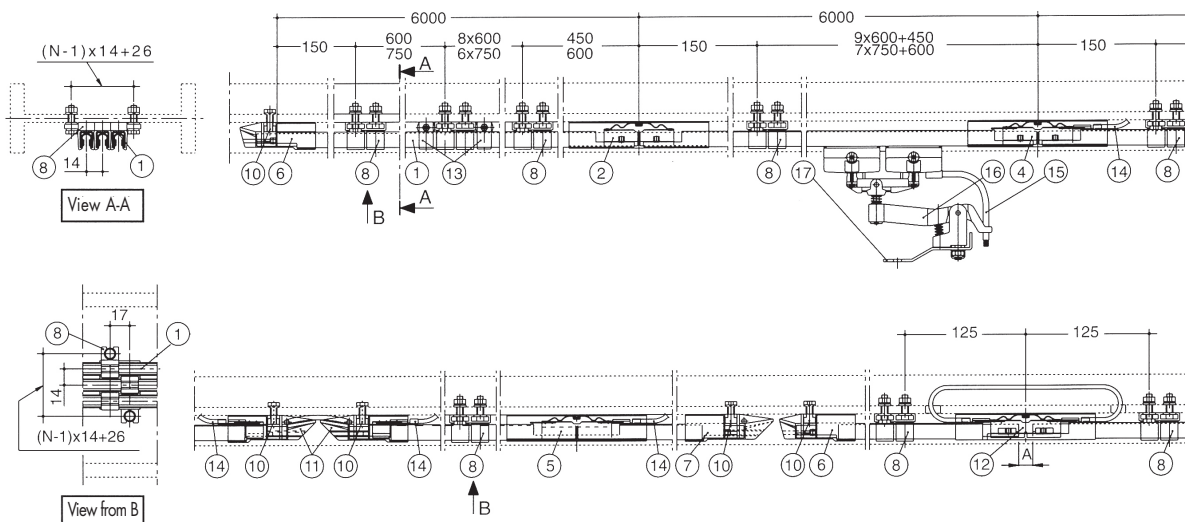

Solution with support and 8 poles multi-pole joint clamps

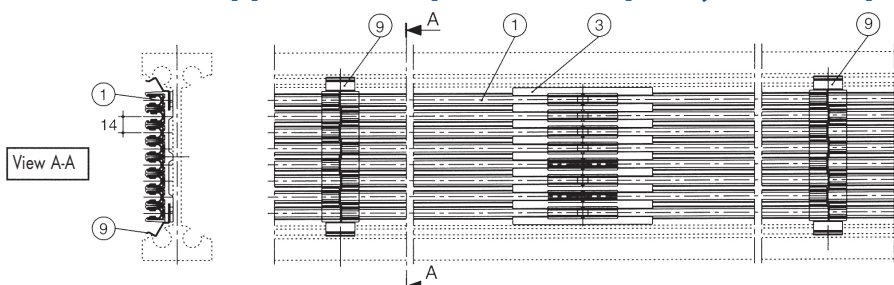

POWERLINE 14

Components

Insulated conductor rail for electrical feeding of cranes

1 Insulated contact rail**FEATURES:**

This consists of an Ω shaped conductor inserted into an insulated PVC housing, orange for the phases and yellow/green for earth. The Ω shape allows self-centring of the current collector shoe and guarantees the best contact with the conductor. Two rectangular slots are made at the two ends of the conductor section for click coupling with the joint clamp. It is supplied in standard straight bars 6 m long. Curves are bent on-site using the appropriate tool. Rail sections pre-curved in the workshop can be supplied.

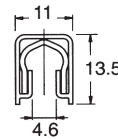

CODE	LOAD (A)	MATERIAL	COLOUR	COND.
03.01401.90	100	rame	Orange	phase
03.01401.90T			Yellow/green	earth

LENGTH	DISTANCE	DISTANCE	RADIUS
6 m	14 mm	for straight sections: 0,75 m	0,4 m
		for curved sections: 0,3 m	

2 Single pole joint clamp**FEATURES:**

CODE: **03.01404.90**

Used to connect two sections of rail. It consists of an insulating body whose configuration guarantees the continuity of insulation and of an internal harmonic tinned steel clamp. The click-fit joint allows fast assembly without using special tools.

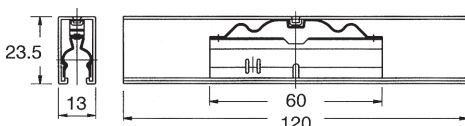
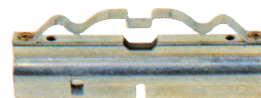
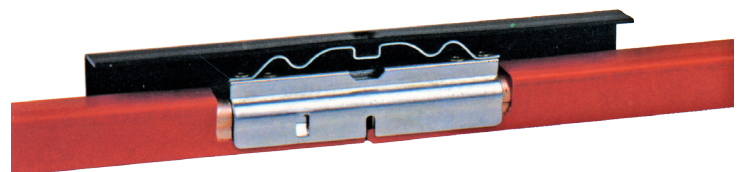

Insulated conductor rail for electrical feeding of cranes

3 Feeder clamp between two rail sections

FEATURES:

CODE: **03.01406.91**

This connects the feeder cable to the rail and also acts as a joint.

It consists of an insulating body containing a harmonic tinned steel clamp fitted with two brass male terminals for connecting the quick-release female terminals fitted to the feeder cable.

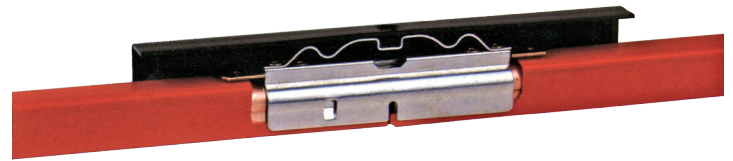
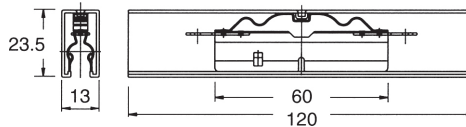

4 Straight transfer terminal

FEATURES:

CODE: **03.01408.90**

Used to interrupt the rail for creating insulated sections and/or interruptions in correspondence with points and lifting sections. It can be either without or with feeding. In the version without feeding the terminal consists of an insulating body with a funnel entry to be fitted to the end of the rail. The version with feeding is complete with the proper harmonic tinned steel clamp fitted with a brass male terminal for connecting the quick-release female terminal fitted to the feeder cable.

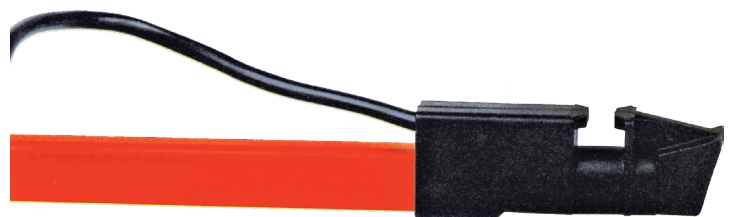

CODE	TYPE
03.01408.90	with feeding
7.21.00.0575	without feeding

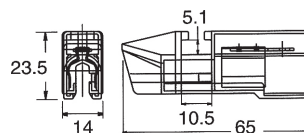

4 Oblique transfer terminal

FEATURES:

CODE: **03.01409.90**

Used to interrupt the rail for creating insulated sections and/or interruptions in the system in correspondence with points and lifting sections. It can be either without or with feeding. In the version without feeding the terminal consists of an insulating body with a funnel entry to be fitted to the end of the rail. The version with feeding is complete with the proper harmonic tinned steel clamp fitted with a brass male terminal for connecting the quick-release female terminal fitted to the feeder cable.

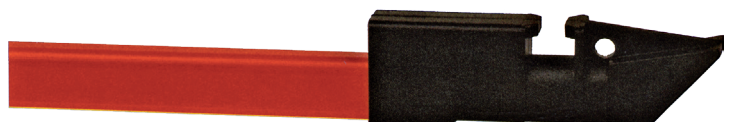

CODE	TIPO
03.01409.90	with feeding
7.21.00.0576	without feeding

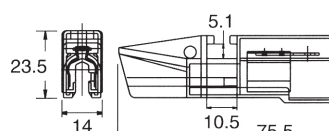

5 Single pole support hanger

FEATURES:

CODE: **7.21.00.0587**

Used to support single rail. It is made so that several clamps can be fitted together to create a multiple support according to how many rails are required by the application. The complex thus created is fixed to the support beam with two screws.

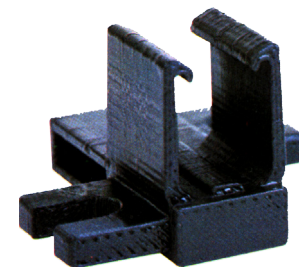
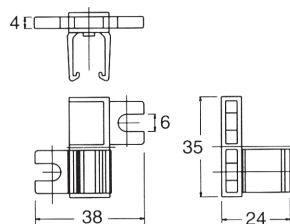

6 Sectionalizing joint

FEATURES:

CODE: **03.01412.90**

This is used to create cut-out sections for performing commands, sections with a separate feeding or sections isolated for maintenance purposes. It can be with or without feeding. The version without feeding consists of two oblique insulated terminals coupled by a spacer. The version with feeding is complete with the proper harmonic tinned steel feeder clamp fitted with a brass male terminal for connection to the quick-fit female terminal fitted to the feeder cable. All oblique insulated terminals are fitted to the end of a section of rail.

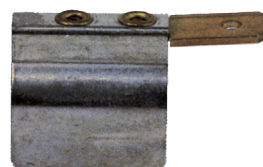

CODE	TYPE
03.01412.90	with feeding
03.01412.91	without feeding

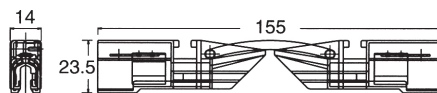

7 Expansion joint

FEATURES:

CODE: **03.01416.90**

This compensates the rail expansions due to temperature variations. It is used for very long lines as required by the system. It consists of two sections of rail with a total length of 800 mm and a feeder clamp. Each section of rail has a slot at one end for connecting the adjoining rail sections. The other end has special elongated slots which allow an excursion of 24 mm. of the feeder clamp on the rail conductor. The feeder clamp is fitted with brass male terminals for quick coupling to the connecting cable, which electrically shunts the expansion joint.

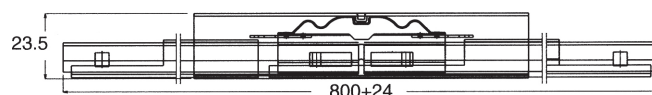

CODE	LOAD	MATERIAL	COLOUR	COND.
03.01416.90	100 A	rame	Orange	phase
03.01416.90T			Yellow/green	earth

8 Fixed point clamp

FEATURES:

CODE: **03.01276.90**

A pair of fixed point clamps are fitted to the sides of the support hanger complex or the multi-pole support for each of the contact rails. Fitted halfway along the system or between two adjacent expansion joints, it creates a fixed point to transfer the expansion at the end of the line or to the nearest expansion joint. The clamp consists of two insulating half-shells joined together by a locking screw, allowing the clamp to be locked fast to the rail's insulated profile.

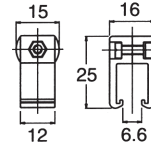

9 Feeder cable for rail

FEATURES:

CODE: **03.01424.90**

This is used to feed rail in correspondence with feeder clamp, transfer terminals and sectionalizing joints as required by the system. The feeder cable consists of a preinsulated quick-fix female terminal fitted to the end of an insulated flexible cable 1 m long. The connection is made by pressing the female terminal into the male terminal of the feeder clamp, transfer terminal or sectionalizing joint.



CODE	SECTION	COLOUR	USE
03.01424.90	4 mm ²	Black	phase
03.01424.90T		Yellow/green	earth

10 Current collector connection cable

FEATURES:

CODE: **03.01286.91**

Used to supply the current collector, by being pressed into the male terminal of the current collector shoe. It consists of terminal fitted to the end of a flexible cable 1 m long.

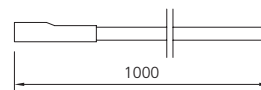

Insulated conductor rail for electrical feeding of cranes

11 Current collector - load 25 A**FEATURES:**CODE: **03.01282.91NM**

It is articulated in all directions and fully isolated. The sliding contact is realized by metallic carbon shoe and can be removed. A proper flexible cable with pressure lug, to be ordered separately, is used for the electric connection.

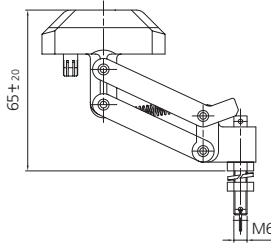

CODE	WEIGHT (kg/pc)
03.01282.91NM	0,040

SPARE PARTS**12** Contact shoe for current collector

CODE	WEIGHT (kg/pc)
713000049M	0,010

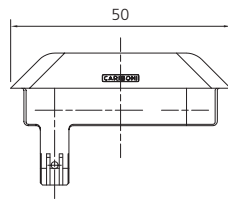
**13** Professional tool for shearing slots at the extremities of the rail**FEATURES:**CODE: **03.01420.90**

This is intended for regular installers of electrified monorails (EMS) to facilitate assembly of 8-10 pole lines or when numerous sections of special length are planned and rail sections other than standard are to be installed. The tool is used to cut the special rectangular slot at the end of the rail's conductor and has been designed to allow shearing on the bench using a pliers system.

CODE	TYPE
03.01420.90	A

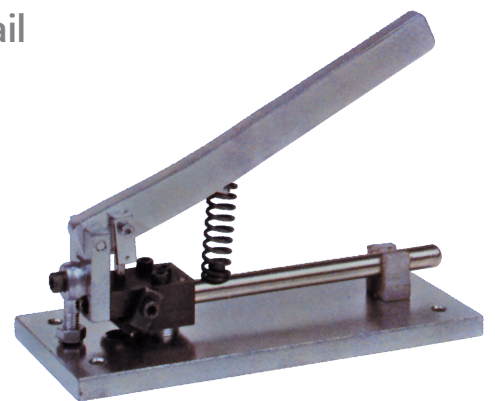
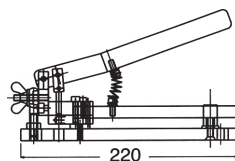

14 Standard tool for shearing slots at the extremities of the rail

FEATURES:

CODE: **03.01420.91**

This tool is used for cutting on the bench with a separate punching system, so its use is recommended for one-off (not repetitive) installations and/or where numerous sections or special length are not planned. It is used to cut the required rectangular slot at the end of the rail's conductor when it is required to cut the standard length section to produce sections of a different length.

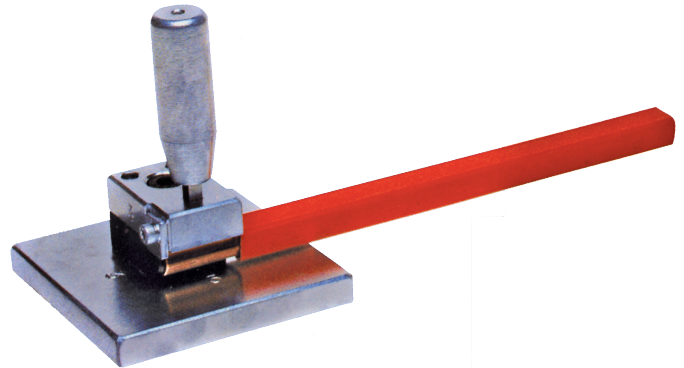
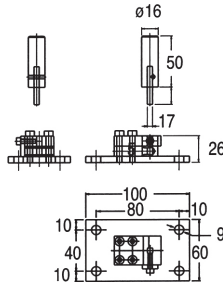

CODE	TYPE
03.01420.91	B

15 Bending tool for rail

FEATURES:

CODE: **03.01296.91**

This is used to make curved sections starting from standard rail sections. Concave and convex curves can be bent on both axes of the rail (vertical and horizontal). The rail is curved gradually by consecutive passages through a group of rollers (calender type) with an adjustable position, thus allowing curved sections of the required radius to be realized.

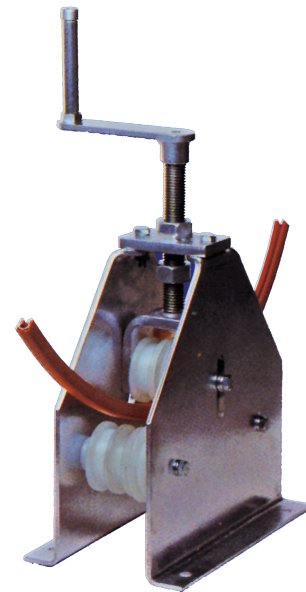
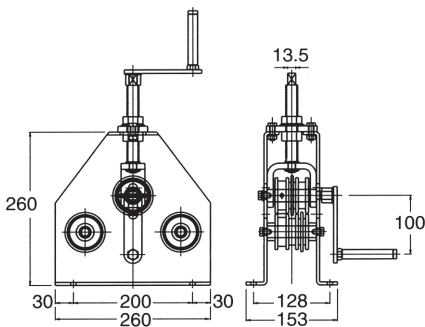



Certificat

Certificate

N° 2012/43392.3

AFNOR Certification certifie que le système de management mis en place par :
AFNOR Certification certifies that the management system implemented by:

ALSTOM FERROVIARIA Spa

pour les activités suivantes :
for the following activities:

CONCEPTION, FABRICATION DE SYSTEMES DE RAILS CONDUCTEUR,
CONCEPTION ET FABRICATION D'ACCESSOIRES POUR LIGNES ELECTRIQUES BT-MT-HT,
COMPOSANTS ET SYSTEMES POUR LA TRACTION ELECTRIQUE,
CONCEPTION ET FABRICATION D'EQUIPEMENTS DE PROTECTION ET MANOEUVRE BASSE TENSION.

PROGETTAZIONE E FABBRICAZIONE DI LINEE DI ALIMENTAZIONE ELETTRICA TRAMITE ROTAJA,
PROGETTAZIONE E FABBRICAZIONE DI ACCESSORI PER LINEE ELETTRICHE IN BT-MT-AT,
DI COMPONENTI ED IMPIANTI PER TRAZIONE ELETTRICA,
PROGETTAZIONE E FABBRICAZIONE DI APPARECCHIATURE DI PROTEZIONE
E MANOVRA PER BASSA TENSIONE.

DESIGN, MANUFACTURING OF CONDUCTOR RAIL SYSTEMS,
DESIGN AND MANUFACTURING OF ACCESSORIES FOR LV-MV-HV ELECTRICAL LINES,
COMPONENTS AND SYSTEMS FOR ELECTRIC TRACTION,
DESIGN AND MANUFACTURING OF LOW-VOLTAGE PROTECTION AND CONTROL EQUIPMENT.

a été évalué et jugé conforme aux exigences requises par :
has been assessed and found to meet the requirements of:

ISO 9001 : 2008

et est déployé sur les sites suivants :
and is developed on the following locations:

Via Roma 14 - 23855 PESCATO - ITALIA

Ce certificat est valable à compter du (arrêté/valid from)
This certificate is valid from (issued/validity)

2017-03-23

Jusqu'à/au
Until

2018-04-10

Ce document est signé électroniquement à l'aide d'un logiciel technique à valeur probante.
This document is electronically signed with a software of technical value.

Franck LEBEUGLE
Directeur Général d'AFNOR Certification
Managing Director of AFNOR Certification



Not to be used electronically, unmodified or modified, for the purposes of certification or registration. The electronic version only available at www.afnor.org
Non è da utilizzare elettronicamente, non modificata o modificata, per scopi di certificazione o registrazione. La versione elettronica è disponibile su www.afnor.org

Flâchez ce QR Code
pour vérifier la validité
du certificat

